

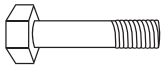

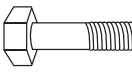

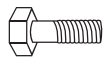

PARTS INCLUDED:

- | | |
|-----------------------|--------------------------|
| 1 Horizontal Brace | Straight Bar Attachment |
| Top Pulley Brace | Lat Pull-Down Attachment |
| Bottom Pulley Brace | 6 Pulleys |
| Metal Upright | 2 Plates for Pulleys |
| Weight Carriage | 2 Pole Tubes |
| Weight Peg Crossbrace | 6 Carabiners |
| 2 Spring Clips | 2 Cables |
| | Rubber Foot |

HARDWARE INCLUDED:

3 In Bolt x 9 	2 In Bolt x 3 	1.125 In Bolt x 2 	.75 In Nut x 12 
Black Spacer x 6 	.875 In Washer x 24 	.75 In Washer x 4 	.5 In Nut x 2 

1.

Replace back pullup bar with horizontal brace.

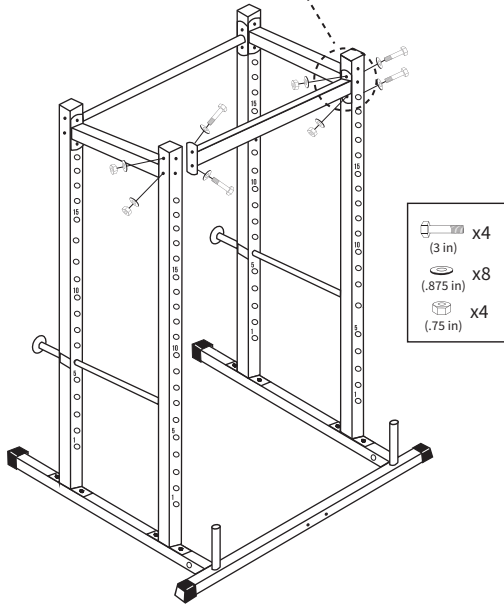

2.

Secure top and bottom pulley brace of lat pull down to crossbars of the rack.

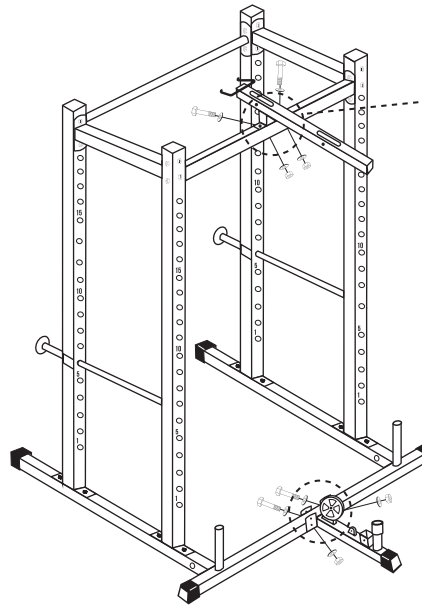

3.

Slide weight carriage onto metal upright.

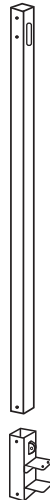

4.

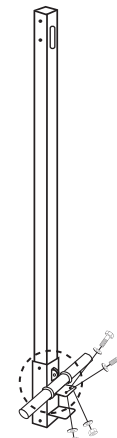
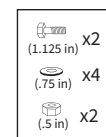

Attach weight horns to the weight carriage.

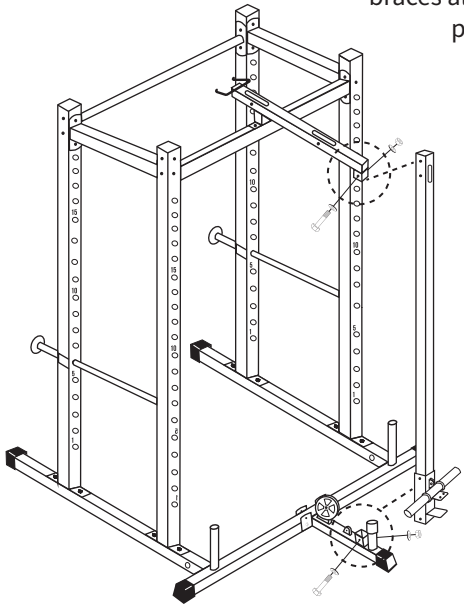

5.

Secure metal upright to pulley braces already attached to power rack.





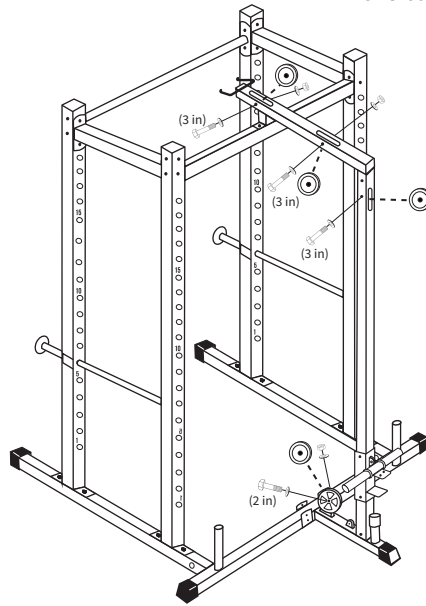

-  (3 in) x2
-  (.875 in) x4
-  (.75 in) x2

6.

Attach pulleys to their designated spots (there should be two that are not being attached yet as they need the cable to be secured).





-  (3 in) x8
-  (2 in) x1
-  (.875 in) x16
-  (.75 in) x8
-  x8

7.

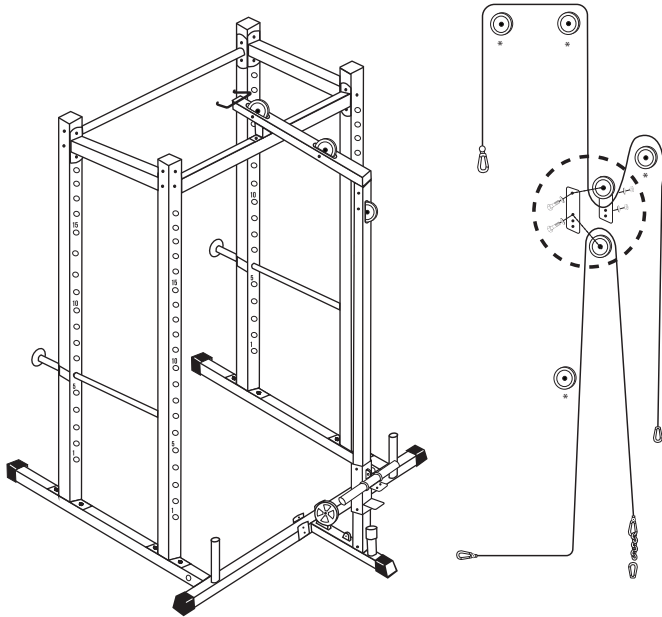
Feed cables through pulleys and secure the last two pulleys in their designated location. One end of each cable will attach to the base of the lat pull down to create a line of tension and the other will have a carabiner to attach pull-down accessories.



-  (2 in) x8
-  (.875 in) x16
-  (.75 in) x8

8.

Clip your pull-down accessories to the carabiners.

